

MOVEMENT SENSOR 180°(WALL MOUNTING)

T 76 252

Technical Manual

Toyama Movement sensors are intelligent lighting control energy saving sensitivity detectors. Movement sensors use Passive infrared (PIR) sensor to detect the human movement and make corresponding triggering of loads, say lights. Usage of SMD components not only ensures reliability but also makes the product highly compact for its functionality and features. Wide operating voltage range of the Movement sensors makes it operational across countries from North America having 127V supply to European countries with 230V supply without any field setting. The device is incorporated with the adjustable inbuilt timer to switch OFF the load when there is no human movement. The device is also incorporated with Lux detector.

Applications: Movement sensors can be installed in

- Office /Hotel corridors.
- Stair cases/Passage.
- Stores, Classrooms.
- Common fresh rooms.

SPECIFICATIONS:

Supply voltage	:	110 - 250V/AC
Supply frequency	:	50-60 Hz
Rated load	:	1200W
Detection angle	:	180 °
Detection distance	:	20 feet
Installation height	:	8-9 feet optimum
Detection motion speed	:	0.6 - 1.5m/s
Time – delay	:	Minimum: 30 sec / Maximum: 450 sec
Lux adjustment level	:	10 – 400 lux
Power consumption	:	0.45W (Static 0.1W)
Operating Temperature	:	0 - 55°C
Standard color of Movement sensor	:	White

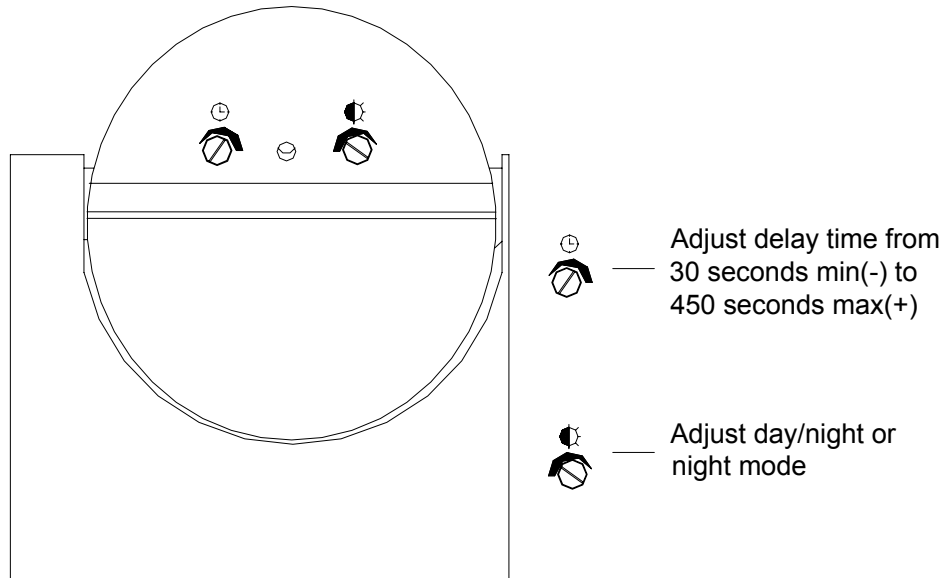

Please read the instructions before installing:

- Movement sensors should be preferably installed by a trained electrician who can understand the installation procedure and guidelines.
- Ensure wires are properly connected with reference to phase, neutral and load.
- Concentrated Light from IR emitting fluorescent lamps should not fall on the sensor window, which may disturb the sensing operations. As such ensure a minimum distance of around 3 meters between the florescent lamp and the movement sensor.
- Install the movement sensor only at the specified height
- Install the movement sensor in such a way that the detection range is angled across the movement.
- Use only transformers/Ballast made to IEC or equivalent standards by manufacturers of repute.
- If required connect 2.2uF/440V AC Fan Capacitor across CFL with electronic ballasts to avoid blinking in OFF state.
- Connect upto specified wattage of load only. For higher loads suitable rated contactor of reputed make can be used.
- Hindrance / moving object should not hide the detection window.
- Avoid installing in Bathrooms. Make sure air conditioners, central heating, etc.do not cloud IR window.

INSTALLATION OF MOVEMENT SENSOR– Steps:

1. Turn OFF power through the MCB.
2. Remove the bottom lid from the sensor by loosening the screws.
3. Fix the bottom lid in the selected position with the inflated screws
4. Connect the movement sensor as per the wiring diagram shown below.
5. Mount the sensor on the bottom lid and screw it.
6. Turn ON power through the MCB.

WIRING DIAGRAM OF MOVEMENT SENSOR:

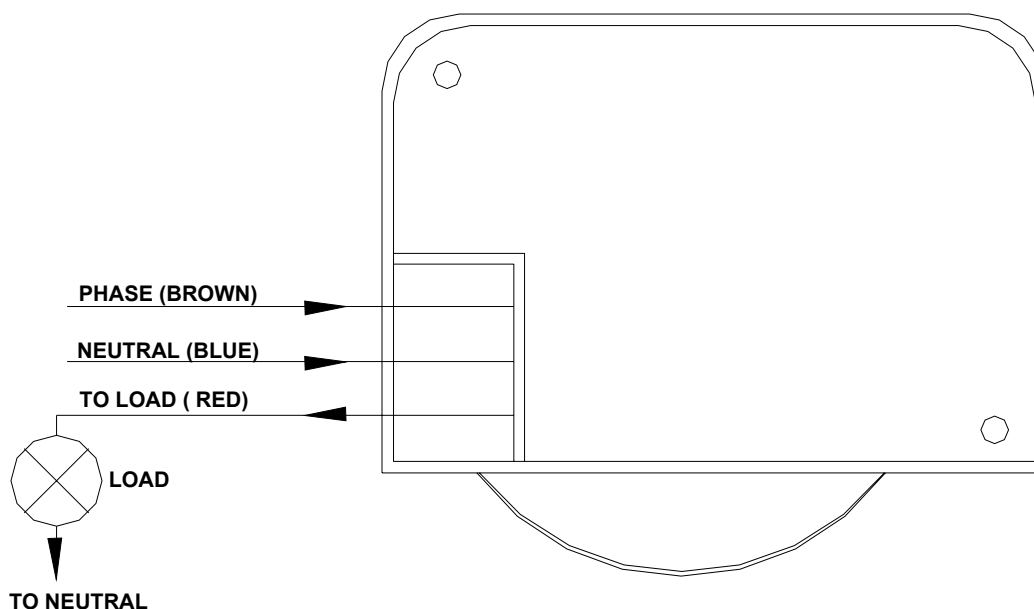

Note: Use 0.75 Sq.mm.flexible wires for connections (Phase, neutral & load)

OPERATION:

- ◆ **Detection field:** The detection field is made up of up and down, left and right service field. (See the following diagram). But it has the relationship between the sensitivity and the orientation of moving. Detection distance can be set according to the installation position and detection field.
- ◆ **Time-delay adjustment:** The timer knob can be set according to the customer needs. The minimum is 30 sec. and the maximum is 450 sec delay OFF.
- ◆ **Identifies day and night automatically:** When the trimmer knob is turned towards SUN Position (max), it can work at the day and night. When turned towards MOON position (min), the sensor will only at night (less than 10LUX ambient light)

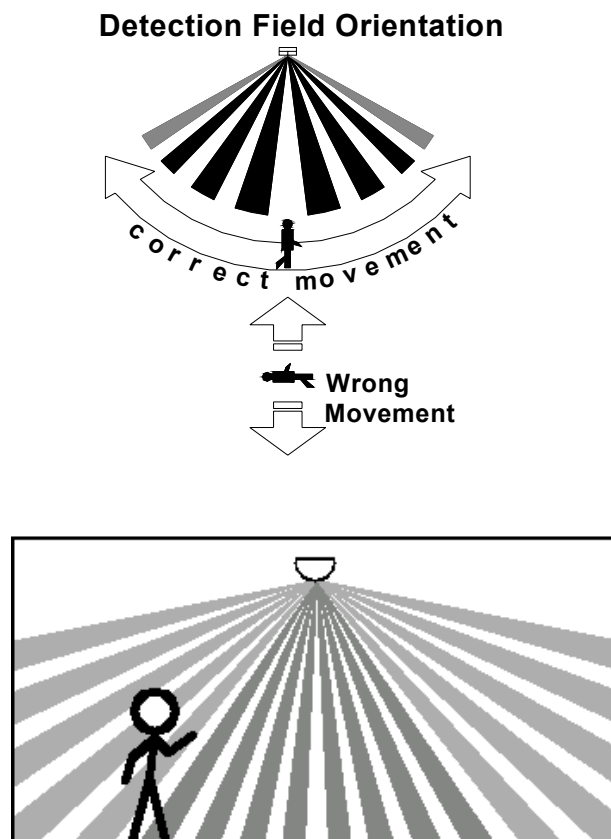

At a distance closer to the sensor, even slow movement can be detected. As the movement is away from the sensor, the space between the zones of sensitivity increases, and therefore the amount of motion required to trigger the device increases.

TROUBLE SHOOTING:

Symptom	Possible cause	Remedies
Lights do not ON	<ul style="list-style-type: none"> Light(s) burned out. Breaker is OFF or tripped. Wiring error Lux level adjuster (Photo) may be in moon mode. 	<ul style="list-style-type: none"> Replace the bulbs Switch ON the breaker. Check and correct the connections Turn the lux level adjuster (photo) fully clockwise.
Sensitivity is poor	<ul style="list-style-type: none"> Installation height may be high. Incorrect moving orientation Obstruction in front of sensor window 	<ul style="list-style-type: none"> Install at recommended height. Correct moving orientation Remove the obstruction in front of the window

DIMENSIONS:

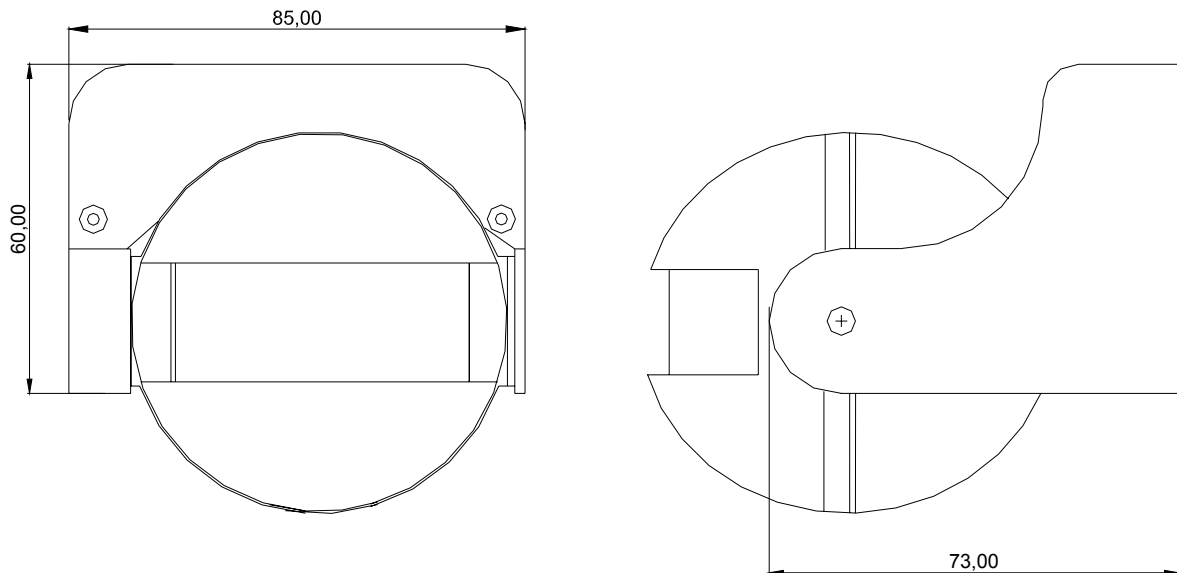

ALL DIMENSIONS ARE IN mm